

Single or Dual Band Operation

CodeRunner 2 uses a "2 box" design with an Indoor Unit providing controls, analog and video modulation, and several options for internal or external COFDM modulation and MPEG encoding.

CodeRunner 2 offers broadcasters several options for current and future expansion. The Indoor Unit can be configured for single or dual band operation in combinations of 2, 7, or 13 GHz. In dual band configurations, separate RF Units for each band are required. In addition, you can switch between 2 mast mounted antennas from the Indoor Unit using MRC's RF Antenna Switch.

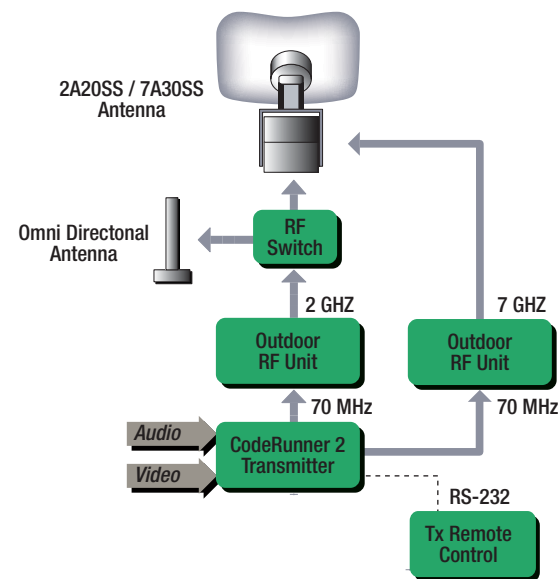

2/7 GHz CodeRunner 2 Dual Band System with Separate RF Units

New or Existing Installations...

CodeRunner 2 can be installed into an existing news van using the current wiring, or by installing a triax interconnection cable between the Indoor and Outdoor Unit. The triax cable is extremely lightweight compared to traditional multi-cable wiring harnesses, and provides power, control, and diagnostic signals – all multiplexed into a single cable.



CodeRunner 2 in existing van installation (left). SUV Installation with Omni Directional and MegaHorn Antenna (right)

Analog to Digital Transition...

In 1998, MRC successfully tested the CodeRunner transmitter using MPEG Encoding and COFDM Modulation in various stationary, mobile, and airborne applications. The results were astounding. This revolutionary breakthrough allowed news teams to broadcast from locations that were previously impossible with analog radios.

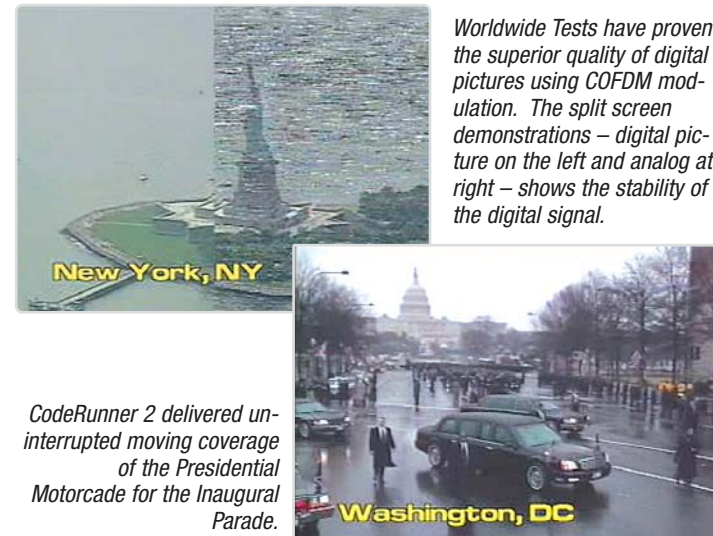

Worldwide Tests have proven the superior quality of digital pictures using COFDM modulation. The split screen demonstrations – digital picture on the left and analog at right – shows the stability of the digital signal.

CodeRunner 2 delivered uninterrupted moving coverage of the Presidential Motorcade for the Inaugural Parade.

CodeRunner 2 provides several upgrade paths and antenna options. From a basic analog system, MRC offers several COFDM modulator and MPEG encoder options to transform the system into a full analog/digital system.

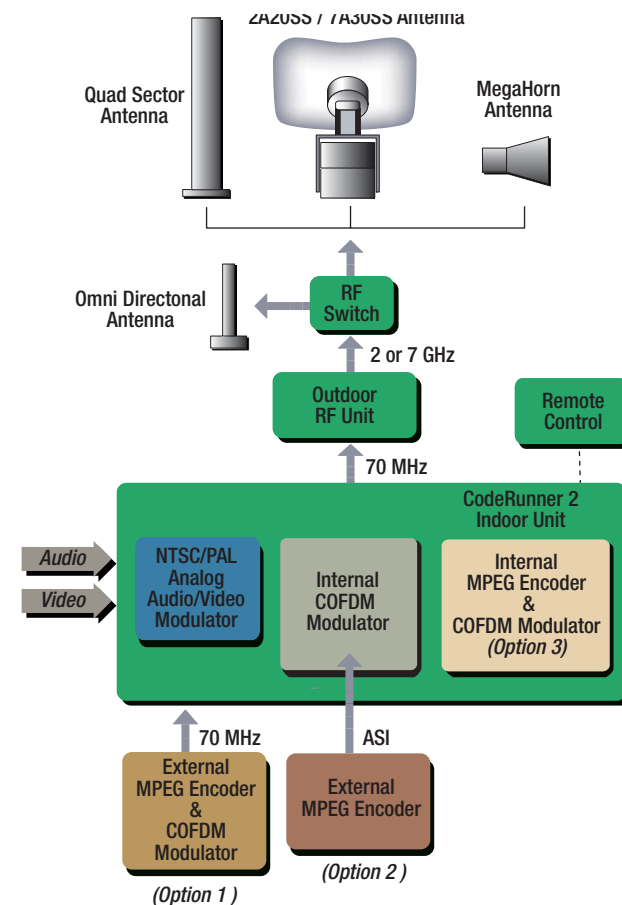

CodeRunner 2 upgrade options using internal and external modulators and encoders.

CodeRunner 2 Menu System

CodeRunner 2's menu system provides easy access to all radio functions. A "safety timeout" locks the menus to prevent inadvertent changes to settings. Screen contrast for various lighting conditions can be adjusted along with a timeout feature to turn off the screen.



Front Panel Active Display ...

- Analog or Digital mode
- Band, Channel, and Offset
- Channel Bandwidth (12 or 17 MHz)
- Power Amp – High or Low Power
- Local or Remote Mode
- Transmit Power

Indoor Unit Menu Features

Configuration	Screen Contrast, Screen backlight timeout, Power Amp Calibrate, Power Amp Mode, Remote Control Menu, Enable/ Disable, Modem Baud Rate
Remote Control	Enable/Disable, Tx/Rx Baud Rate
Channel Plan	Set Frequency/Offset, Save Settings
Audio Modulator	Status
Video Modulator	Status, Mode
Digital Modulator	Status, Internal/External Modem Auto-detect, Modulation
Internal COFDM DVB-T	Modulation, Guard Interval, Data Rate, Status, Forward Error Correction, Attenuation
Color Bar Generator	Auto/Standby, Tones/Bars, Mute, Enable/Disable
IDU Power	+5, -15, +15, +24 Vdc, RF Unit Voltage (Current, Minimum, and Maximum Readings)

Outdoor Unit Menu Features

Main Menu	Frequency, UHF Converter Lock/Unlock, Channel, Offset, Transmit Power, Power Amp On/Off, Power High/LowBand, Local, Oscillator Phase Lock, Loop Lock/Unlock
RF Unit Power Supply	+15 Vdc, Head Voltage, Power Amp Current (Current, Minimum, and Maximum Readings)

Antennas



2A20SS/7A30SS

- Low-profile, offset-fed
- Single or Dual Band
- 2 GHz and 7 GHz
- Linear or circular quad polarization



Omni Directional

- Compact Size (1.5"D x 9" H)
- 2 GHz and 7 GHz
- 2 dBi or 5 dBi Gains



MegaHorn

- High gain
- 2 or 7 GHz
- Linear or circular polarization

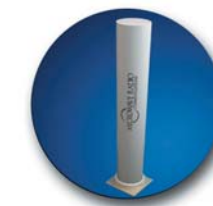

Quad Sector

- Provides an omni-directional and high-gain antenna for digital COFDM news gathering systems
- 16 dBi gain
- 1.99-2.50 GHz
- Vertical polarization

CodeRunner 2 Options

Remote Control Panel

Designed for quick access to most common functions, the Tx Remote Control installs in a standard helicopter or vehicle front panel mount. A sensor measures cabin light to adjust the intensity of the display.

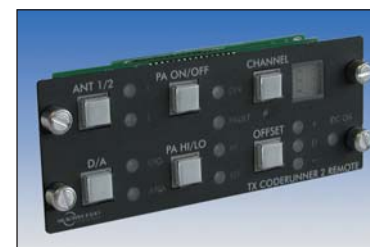

CodeRunner 2 Remote Control

Integrated MPEG & COFDM

CodeRunner 2 is available with a plug-in MPEG and COFDM module.



MPEG Encoder & COFDM Modulator Plug-in Module